

Sentinel™ EFI-MLZ

EARTH FAULT INDICATOR

USER'S MANUAL

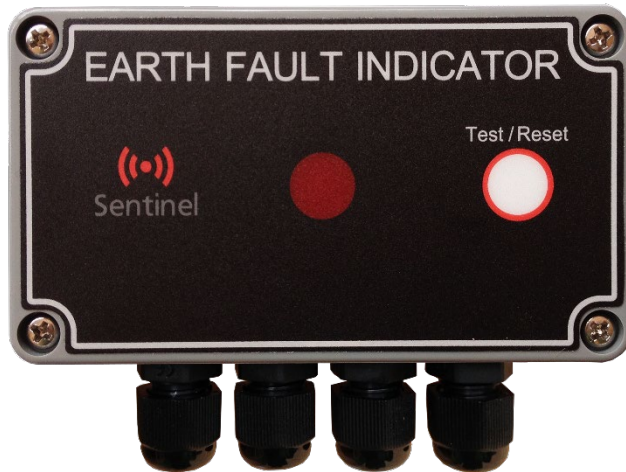

CONTENTS

1. SAFETY NOTICE.....	3
2. OVERVIEW.....	4
3. FEATURES.....	4
4. INSTALLATION.....	4
4.1 CURRENT SENSOR.....	4
4.1.1 MULTI-CORE CABLE SYSTEM.....	5
4.1.2 SINGLE-CORE CABLE SYSTEM.....	7
4.2 INDICATING UNIT.....	7
4.3 REMOTE INDICATOR (OPTIONAL).....	8
5. OPERATION.....	8
5.1 CURRENT SENSOR.....	8
5.2 INDICATING UNIT.....	9
5.2.1 AUXILIARY RELAY (OPTIONAL).....	9
5.2.2 REMOTE INDICATOR (OPTIONAL).....	9
5.2.3 MANUAL TEST AND RESET.....	9
6. TESTING.....	10
7. SPECIFICATIONS.....	11
8. ORDERING.....	13
9. WARRANTY.....	15

1. SAFETY NOTICE

Review the following safety precautions to avoid serious injury or death and to prevent damage to this product or any products connected to it. To avoid potential hazards, use this product only as specified. This equipment contains high voltages. Electrical shock can cause serious or fatal injury.

PRECAUTIONS



WARNING: Under certain fault conditions, high voltages can be conducted into the earth fault indicator enclosure through the CT, remote indicator, or the auxiliary relay cables. All parts within the enclosure should be handled as if carrying dangerous voltages.



WARNING: Use extreme caution during the installation and use of the earth fault indicator as high voltages and currents may be present in the circuit.

- Ensure that the current sensor is installed at earth potential on the HV cable system.
- Ensure that the current sensor is installed on the screened part of the cable system.
- Use caution during the installation and use of this product; high voltages and currents may be present in the circuit.
- This product must be used only by qualified personnel practicing applicable safety precautions.
- Wear protective clothing and gloves as required.
- Do not install this product on live conductors.
- Always de-energize circuit before installing the current sensor and indicating unit.
- Always inspect the current sensor, indicating unit and all leads for damage before using the product.
- Do not use the product if damaged.

2. OVERVIEW

The Sentinel EFI-MLZ is one of a family of Earth Fault Indicator (EFI) products that is designed to assist in the rapid location and isolation of earth faults on high voltage cable networks. The EFI can be used in radial networks or in openly operated ringed networks. When an asymmetrical current greater than the trip level (50A default, factory programmable) in a 3-phase cable system is detected, an earth fault is indicated by means of a flashing LED (light emitting diode) indicator. The path of the fault current from the feeding point to the fault location is marked by the triggered EFI's. The defective conductor segment is located between the last EFI which has been triggered and the first EFI which is still inactive.

3. FEATURES

- Mains powered
- LED indication
- Auxiliary relay output contact
- Remote indication driver
- Split-core current sensor
- 50A nominal trip (factory programmable)
- 50ms minimum fault duration
- Manual test and reset facility
- IP65 environment protection
- Rugged and reliable electronics
- ISO9001:2000 based quality assurance
- Electromagnetic compatibility

4. INSTALLATION

4.1 CURRENT SENSOR

The Sentinel current sensor consists of a flexible steel core which is wrapped around the three-phase system to be monitored and fastened tightly in place with adjustable cable-ties. The current sensor is normally shipped fastened in a closed position. The cable-ties are released by depressing the small ratchet on the head while bending back the tail. The current sensor and associated leads must be installed at earth potential on the screened part of the cable and not go anywhere near the unscreened HV system. Also the current sensor should not encircle the cable earthing. This can easily be achieved by looping the earthing lead back down through the current sensor so as to bypass current sensor.

The current sensor is available in three different sizes depending on whether it is to be applied to an installation consisting of a multi-core cable or a system comprising of three single-core cables.

4.1.1 MULTI-CORE CABLE SYSTEM

The Sentinel EFI ships with a standard sized (CT100) current sensor, which is suitable for most multi-core cable systems. A larger current sensor (CT150) is also available but must be specified at time of order. The flexible sensor core is mounted on the screened part of the cable, below the stripback point. The core is wrapped around the cable and the cable-tie is pulled tight as far as it will go. A second cable-tie is used to hold the core firmly onto the cable. The cable screen is turned back underneath the core and then terminated to earth as shown in the Figure 1.

FIGURE 1: CURRENT SENSOR MOUNTED ON MULTI-CORE CABLE SYSTEM

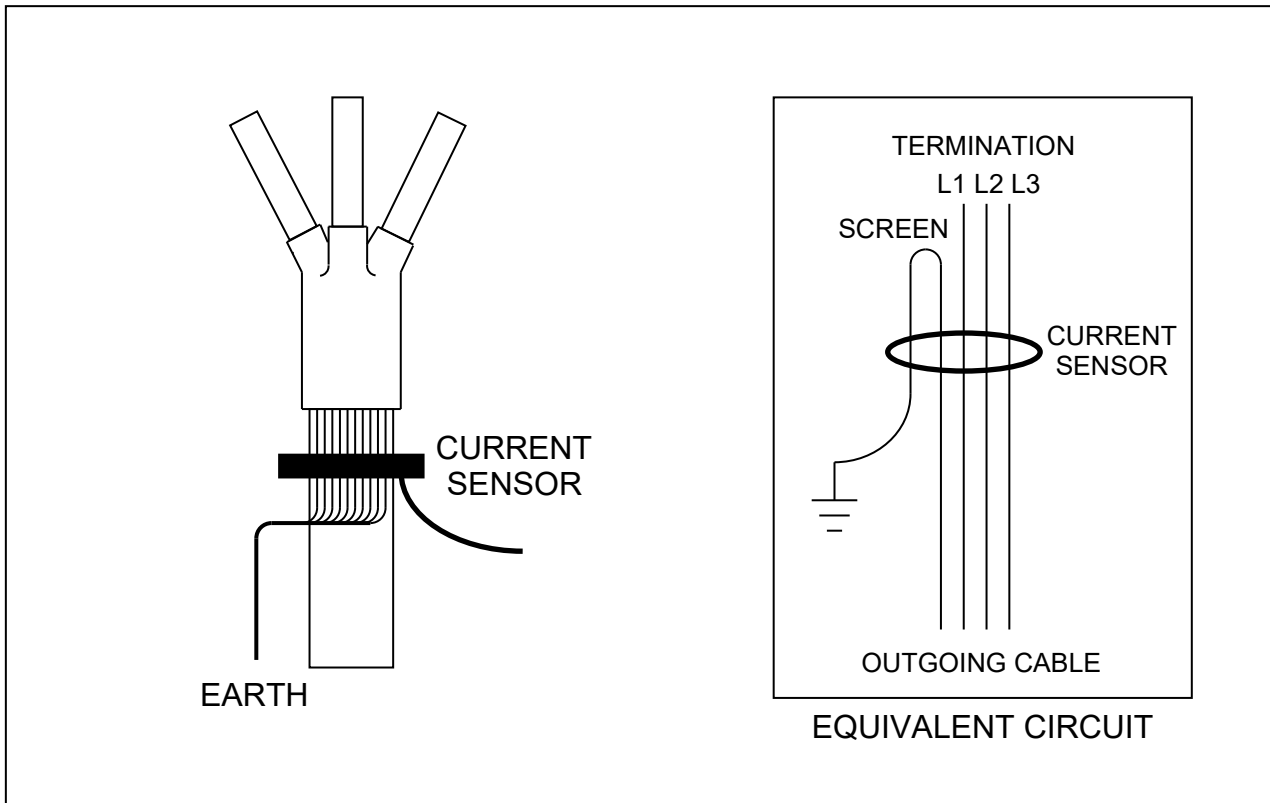
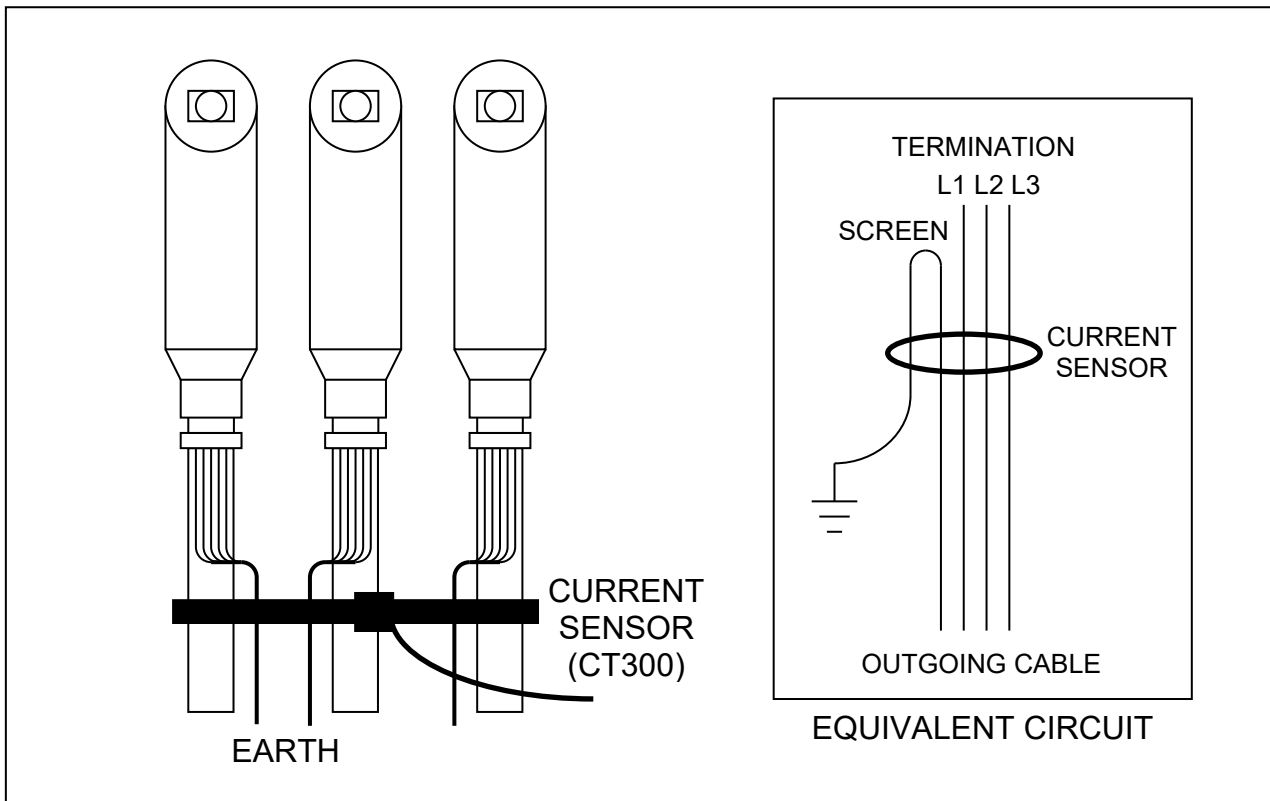

FIGURE 2: CURRENT SENSOR MOUNTED ON SINGLE-CORE CABLE SYSTEM



4.1.2 SINGLE-CORE CABLE SYSTEM

A larger current sensor (CT300) is available for application on single core cable systems. These systems usually consist of three single-core cables spaced in a row, side-by-side. The flexible sensor core is wrapped tightly around all three cables forming a rectangular oval, and fastened in place with cable-ties. Care should be taken to ensure that the core is mounted on the screened part of the cable. The screen of all three conductors should be turned back underneath the core and then terminated to earth as shown in Figure 2.

4.2 INDICATING UNIT

The Sentinel indicating unit is normally flush mounted onto a vertical surface. When the cover is removed, mounting holes are exposed for use in bolting the indicating unit to a surface. The current sensor and other accessories are electrically connected to the indicating unit by feeding the leads through cable glands (PG7) on the indicating unit and connecting them to two-way screw terminals mounted inside the indicating unit enclosure. With the cover and cable glands tightened firmly the enclosure provides IP65 protection.

FIGURE 3: INDICATING UNIT SHOWING TERMINALS AND MOUNTING HOLES

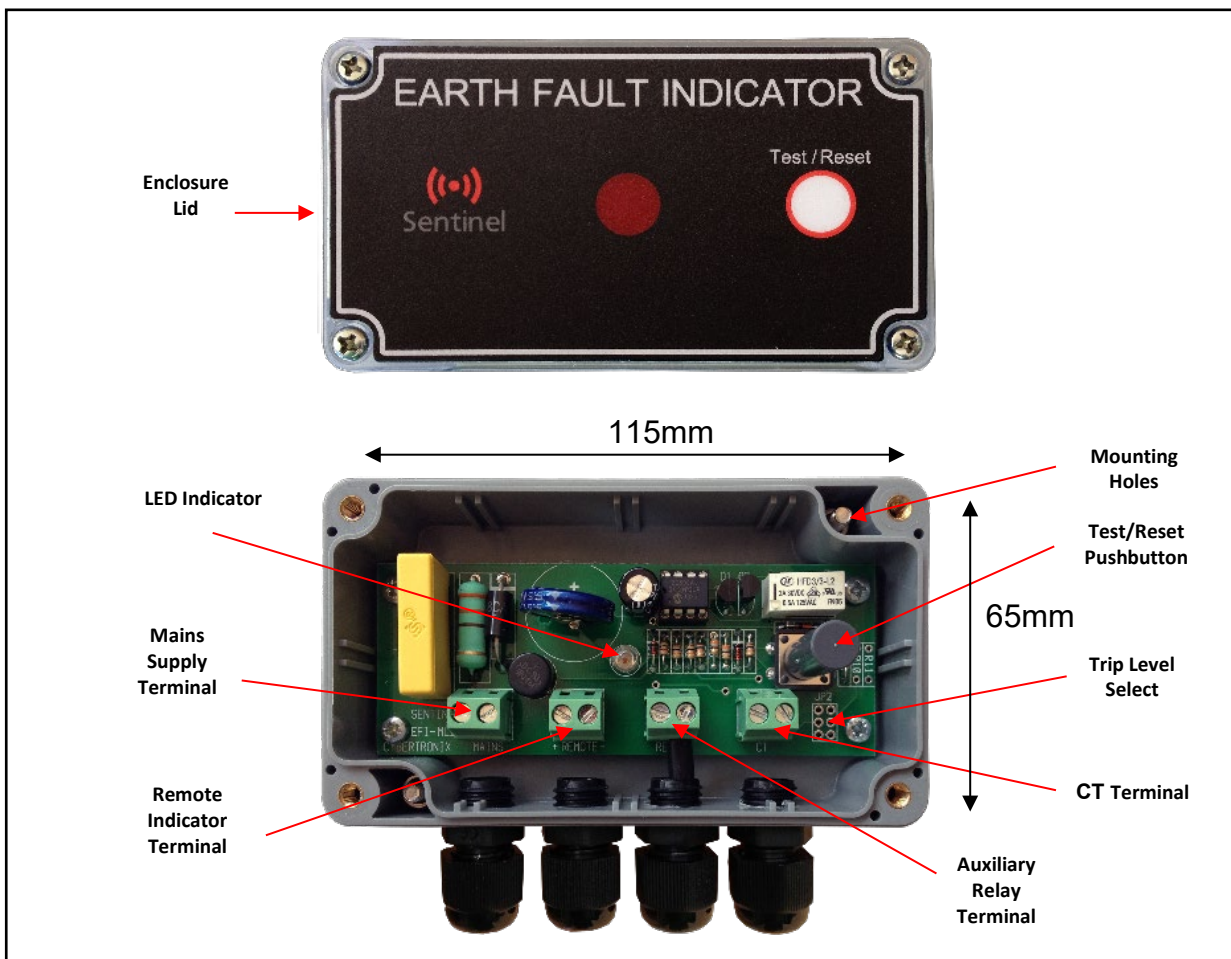

4.3 REMOTE INDICATOR (OPTIONAL)

A remote indicator can be ordered separately or ordered pre-installed. The remote indicator is designed to be mounted through a hole in the switchgear enclosure so that it is visible from the outside.

FIGURE 4: REMOTE INDICATOR

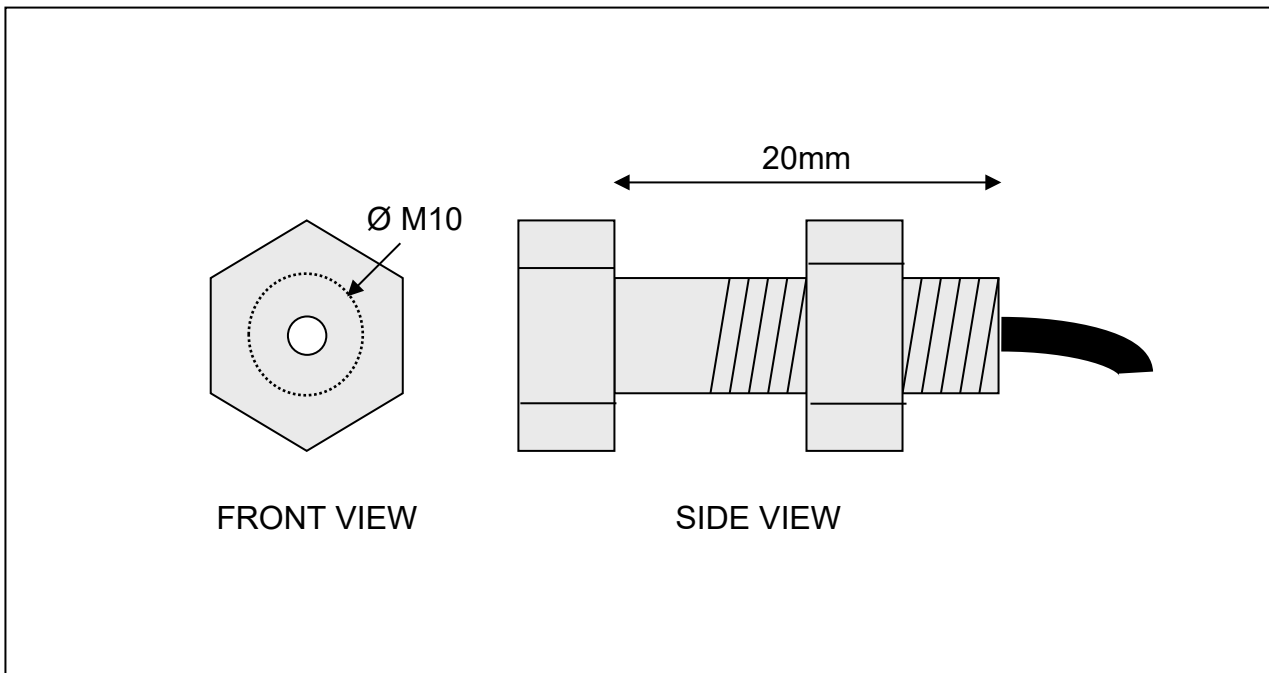

5. OPERATION

5.1 CURRENT SENSOR

The Sentinel current sensor comprises of a flexible iron-core belt with a pickup coil. The belt is fitted around the three-phase cable system being monitored and works on the core-balance current sensing method. Under normal conditions the magnetic flux from the three phase currents summates to zero and the pickup coil generates no voltage output. When an earth fault occurs the summation flux is non-zero and a voltage proportional to the magnitude of the earth fault is generated. The indicator unit has a factory programmable nominal earth fault trip level (default of 50 A). The current sensor has no exposed metal parts and is completely encapsulated and corrosion proof.

5.2 INDICATING UNIT

The primary indication on the EFI-MLZ is a light-emitting-diode (LED). The LED will flash at approximately 1Hz when the EFI is in a tripped state and remain extinguished when the EFI is in a reset state.

The indicating unit is powered from the mains supply and also uses the presence of healthy mains to reset the unit. When healthy mains is first applied or when it returns after a cleared fault condition, the unit will first require up to 5 minutes to charge the onboard supply capacitors before it is functional. The presence of mains voltage will also reset the unit if it is in a tripped state.

The indicating unit continuously monitors the output signal from the current sensor. The current sensor transmits a voltage which is proportional to the measured current. For primary currents in excess of the trip level (default 50A) the current sensor saturates and a limiting circuit inside the indicating unit clamps the output voltage to below 10V even for high fault currents. When an imbalance is detected, onboard circuitry analyses the fault current. The magnitude and duration of the half cycles of fault current are measured. Current spikes and glitches are ignored. As soon as valid fault current has been detected, the Sentinel triggers and enters a tripped state. A trip will initiate flashing of the LED.

5.2.1 AUXILIARY RELAY (OPTIONAL)

An on-board auxiliary relay provides a potential-free, normally-open contact for additional signaling. A 2-way screw terminal is provided on-board to which the user can connect a signaling cable. The auxiliary relay is operated from the same circuitry controlling the LED. Thus when healthy mains is first applied or when it returns after a cleared fault condition, the unit may require up to 5 minutes to charge the onboard supply capacitors after which it then resets. A reset will latch the relay into the reset position (open). A tripped state will latch the relay into a tripped position (closed).

5.2.2 REMOTE INDICATOR (OPTIONAL)

An optional remote indicator can be ordered pre-installed or ordered separately. A 2-way screw terminal is provided on-board for connection of the remote indicator. It provides flashing LED indication at some distance from the main indicating unit. During a tripped state the unit will flash at a rate of about 1Hz. The remote indicator is weather-proof and is housed inside a stainless steel bolt which also makes it vandal-proof. The on-board circuitry which drives the remote indicator requires at least 5 minutes of mains charging when first connected to the mains supply.

5.2.3 MANUAL TEST AND RESET

A pushbutton located on the front panel allows the unit to be manually tested or reset. The button must be depressed for at least 3 seconds before it will activate. This is to avoid accidental operation. The EFI can only be manually tested if the unit has been charged by the mains supply for up to 5 minutes. The manual test feature can both trip and reset the EFI.

6. TESTING

The Sentinel EFI can be fully tested by injecting test current through the current sensor. A test procedure for the default trip level of 50A is suggested below.

1. Connect the device to mains voltage for at least 5 minutes to charge the supply.
2. Inject 40 A for 1 second. The device should not trip.
3. Inject 60 A for at least 50 ms. The device should trip.
4. Apply mains voltage for 10 seconds. The device should reset.

7. SPECIFICATIONS

Network voltage range:	1-36kV
Rated mains voltage:	110V-230V ±20%
Frequency:	50Hz / 60Hz ±20%
Overvoltage withstand:	600V for 48 hours
Impulse voltage withstand:	10kV, 1.2/50us waveform
Trip current:	50A ±10A (factory programmable)
Minimum fault duration:	2.5 cycles (50ms @ 50Hz / 40ms @ 60Hz)
Fault current withstand:	25kA for 1s
Primary indication:	LED, flash rate 1Hz nominal
Flashing duration:	12 hours nominal (6 hours with remote indicator)
Voltage reset:	Healthy mains for 10s
Manual test:	Pushbutton alternately initiates trip and reset
Supply charging time:	5 minutes nominal
Operating temperature:	-20°C to 70°C

Enclosure

-dimensions	115mm × 65mm × 40m
-material	ABS, grey
-mounting	Flush-mounting, two M4 holes
-degree of protection	IP65
-cable gland size:	PG7; cable diameter range 3-6.5mm
-mass:	250g

Current sensor

-CT100 (standard size):	100mm diameter
-CT150 (optional):	150mm diameter
-CT300 (optional):	300mm × 100mm rectangular oval
-material:	Insulated silicon steel
-mounting:	releasable cable-ties
-lead length:	3m
-lead type:	2-core, 0.5mm ² , doubly insulated
-mass:	250g

Auxiliary relay

-type:	Latching, N/O on reset
-rating:	220Vdc, 250Vac, 2A

Remote indicator

-dimensions:	M10 Hex Bolt 20mm long (100g)
-material:	Stainless steel

-mounting:		Self-mounting through single M12 Hole
-lead length:		2m
-lead type:		2-core, 0.5mm ² , doubly insulated
-degree of protection	IP65	
-indication method		Flashing LED
-flash rate:		1Hz nominal
-flashing duration:		6 hours nominal (includes LED primary indication)

8. ORDERING

Table 1 below shows the codes to be used for product ordering. Only the first three code groups need to be specified for the standard versions of the product. The standard versions ships without the items from groups 4, 5 and 6, and with a standard size current transformer (CT100 with 3m lead).

Please review the examples shown overleaf.

TABLE 1: ORDERING CODES

Group 1	Product Range	EFI	Earth Fault Indicator
Group 2	Symbol 1: Power source	M	Mains powered
		B	Battery powered
		C	CT powered
	Symbol 2: Indicator type	L	LED
		F	Flag
	Symbol 3: Glands	Z	Cable glands fitted
Group 3	Nominal trip current in amps	50	50 amps trip level
Group 4	Symbol 1: Mains cable fitted	M	Mains cable
	Symbol 2: Mains cable length in meters	3	3 meters
Group 5	Symbol 1: Remote indicator fitted	R	Remote indicator
	Symbol 2: Remote cable length in meters	3	3 meters
Group 6	Symbol 1: Auxiliary relay fitted	A	Auxiliary relay
	Symbol 2: Auxiliary cable length in meters	2	2 meters
Group 7	Symbol 1-5: Current transformer diameter	CT100	100mm diameter
		CT150	150mm diameter
		CT300	300mm by 100mm
Group 8	Symbol 1: CT fitted	C	Current Sensor
	Symbol 2: CT cable length in meters	3	3 meters

For Example:

ORDERING CODE	DESCRIPTION
EFI-MLZ (standard version)	<ul style="list-style-type: none"> - Mains powered - LED indication - 50A trip (factory programmable) - CT diameter 100mm, 3m lead
EFI-MLZ-M5-R7-A2-CT150-C3	<ul style="list-style-type: none"> - Mains powered - LED indication - 50A trip (factory programmable) - Mains cable, 5m lead - Remote indicator, 7m lead - Auxiliary relay, 2m lead - CT diameter 150mm, 3m lead

NOTE:

- The mains lead is an optional component and must be specified if required.
- The remote indicator is an optional component and must be specified if required.
- The auxiliary relay is an optional component and must be specified if required.
- The unused cable-glands ship with a rubber stopper inserted to maintain sealing integrity.
- The EFI unit ships in a brown corrugated cardboard box.

9. WARRANTY

The Sentinel earth fault indicator electronic hardware and software is copyright Cybertronix cc 1996.

This product is warranted to be free from defects in material and workmanship for a period of twelve months (12) from the date of shipment. Correction shall be in the form of repair or replacement of the defective items or components, freight paid by the customer both ways. Such correction shall constitute a fulfillment of all Cybertronix cc liabilities in respect to said items and components. In no event shall Cybertronix be liable for consequential damage.

No other warranties:

To the maximum extent permitted by applicable law, Cybertronix cc disclaims all other warranties, either express or implied, including but not limited to implied warranties of merchantability and fitness for a particular purpose, with respect to the Sentinel product and accompanying product manual. Cybertronix cc makes no representation or warranty that the product is 'error free', or meets any user's particular standards, requirements or needs.

Disclaimer:

To the maximum extent permitted by the applicable law, in no event shall Cybertronix cc be liable to the user for any special, indirect, consequential or similar damages, including any lost profits or lost data arising out of the use or inability to use the product or documentation or any other data supplied therewith even if the seller or anyone else has been advised of the possibility of such damages, or for any claim by any other party. In the event of the above limitation not applying to the user, then in no case shall the Cybertronix cc liability exceed the original purchase price of the product.